

Technical Data Sheet

SO TILE CAP

PVC TILE SEAL

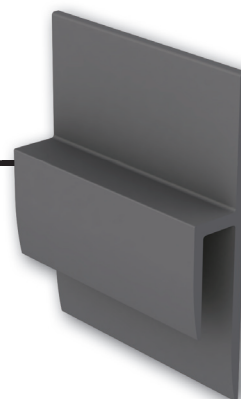

Description

SO TILE CAP is a PVCu tile cap, used where ceramic tiles are finished against a resilient floor finish that has been dressed up the wall to form a skirting.

Installation

Tile caps are used where ceramic wall tiles are finished against a resilient floor finish that has been dressed up the wall to form a skirting, and should be installed prior to the installation of the wall finish.

The tile caps should be allowed to acclimatise for 24 hours prior to installation at an ambient temperature of 18° C.

1. It should be ensured that all surfaces to which the profile is to be fixed are sound, dry, flat and free from any contaminants. Wall surfaces should be free from any previous coverings, linings or adhesive residues used to fix them. Paint films and any mould must be removed and the affected surface treated correctly.
2. Mark the position of the top of the profile on the wall and strike a straight line between the two points using a chalk line.
3. Cut the profile to the sizes required and mitre cut internal and external corners with either a mitre block and hack saw or radial arm "chop" saw fitted with a suitable blade.
4. From the front of the profile, drill 4mmØ pilot holes through the 45mm fixing flange, 40mm in from each end and at centres of 300mm.
5. Apply a suitable adhesive and follow the manufacturers instructions for application.
6. Lining the top of the profile to the chalk line, place against the wall applying firm pressure along the profile's length.
7. Screw the profile to the wall using a no.6 screw (appropriate plug fixing may be required, suitable for accommodating the substrate) through the pre-drilled holes. Steel cork pins can be used as an alternative if the substrate allows.
8. Ensure that any excess adhesive is removed in line with manufacturing instructions.

Technical Data	
Type:	Tile Seal
Environment:	Interior
Used with:	Resilient Floorcovering
Material:	PVCu
Height:	48mm
Gauge:	6mm Resilient Flooring / 7.5mm Tile
Length:	2.5m
Colour:	Snowdrift
Fixing:	Mechanical (Screws) and Adhesive Fix

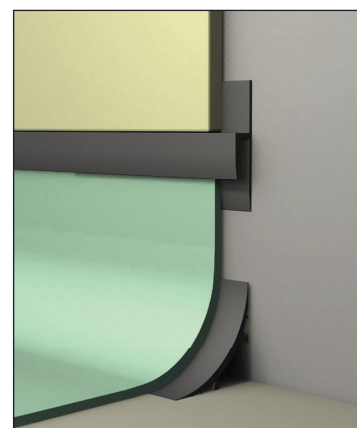
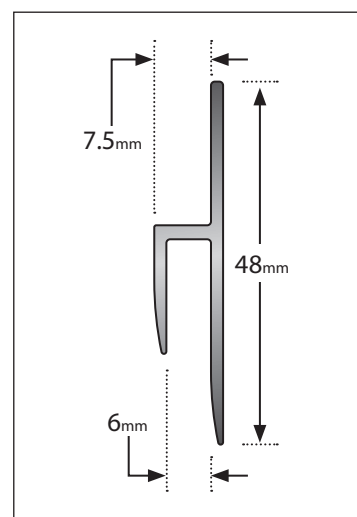

Cleaning and maintenance guidelines:

These guidelines have been compiled to help the user obtain optimum performance and satisfaction.

Preventative Maintenance Programme

- A regular scheduled maintenance programme should be employed to prevent the build up of dirt and grease, which will detract from the overall appearance of the product.

SO TILE CAP

PVC TILE SEAL

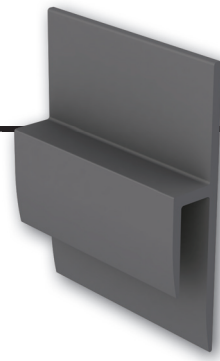

Daily Cleaning

- Brush down the profile using a soft bristled brush and remove dust particles by wiping with a damp cloth.

Twice Weekly or as Required

- Brush down the profile using a soft bristled brush. With clean warm water, apply a small amount of a soap-less detergent to a lint free cloth and gently clean the surface. During the clean, the water must be changed on a regular basis. Once the profile has been cleaned thoroughly rinse with fresh, clean water and dry with a dry lint free cloth. On completion the profile should be completely dry.

NB. The use of an aggressive detergent could result in colour fade within the PVC.

Floor sealants, polishes or such coating should not under any circumstances be applied to PVC.